

## 1 WELLHEAD SYSTEM

1. PREPARE WELL FOR SHUT DOWN
2. RAISE POLISHED ROD TO UNSEAT BOTTOM HOLE PUMP
3. PUMP TO KILL WELL

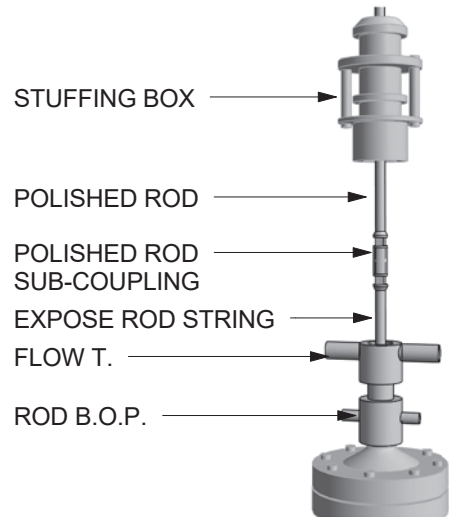

## 2 DISCONNECT COMPONENTS

1. UNSEAT STUFFING BOX
2. LIFT TO EXPOSE SUCKER ROD COUPLING ROD STRING
3. ATTACH ROD ELEVATORS
4. BREAK OFF & LAY DOWN POLISH ROD & STUFFING BOX

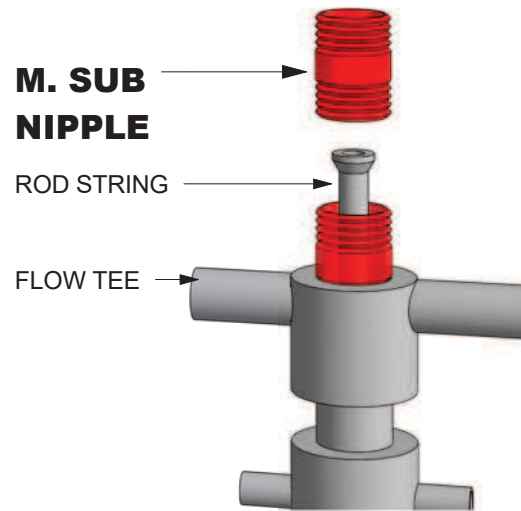

## 3 INSTALL MARKER SUB NIPPLE

1. STRIP OVER (SLIDE ON) MARKER SUB NIPPLE OVER EXPOSED SUCKER ROD
2. INSTALL LANDING ROD
3. RAISE ROD & REMOVE ELEVATORS
4. SCREW NIPPLE INTO TOP OF FLOW TEE

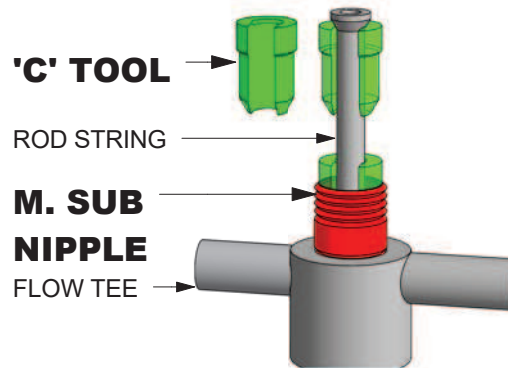

## 4 'C' TOOL INSTALLATION

1. PLACE ELEVATORS ON TOP OF NIPPLE
2. REMOVE LANDING ROD
3. INSTALL 'C' TOOL
4. REMOVE ELEVATORS. CAUSING THE 'C' TOOL TO LAND INTO TOP OF MARKER SUB NIPPLE

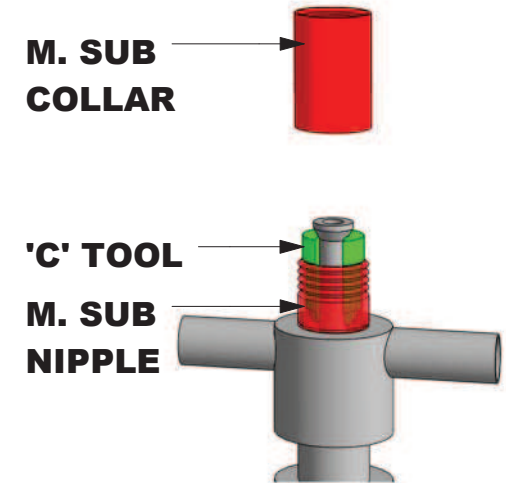

## 5 INSTALL MARKER SUB COLLAR

1. DISCONNECT LANDING ROD
2. STRIP OVER (SLIDE ON) MARKER SUB COLLAR

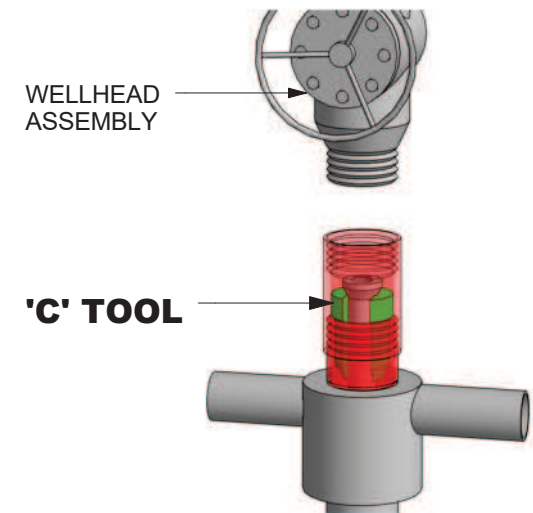

## 6 WELLHEAD INSTALLATION

1. INSTALL WELLHEAD ASSEMBLY